

APPROVED

By Lothar Rosenberger at 8:11 am, Sep 24, 2010

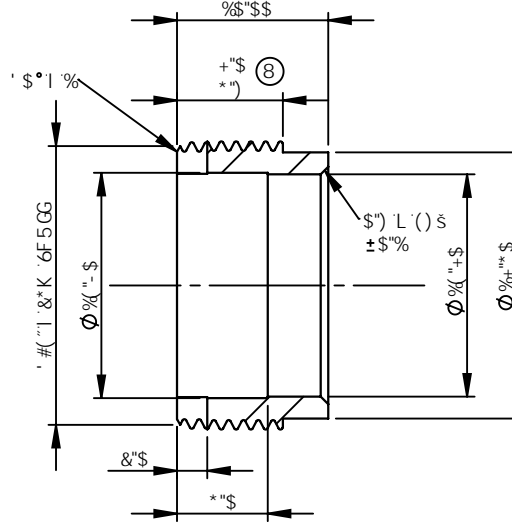
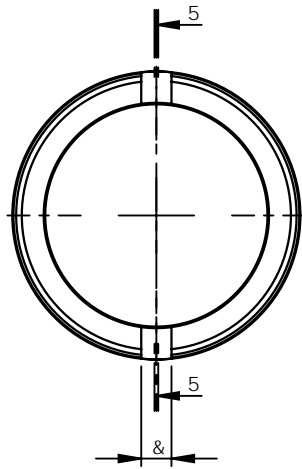
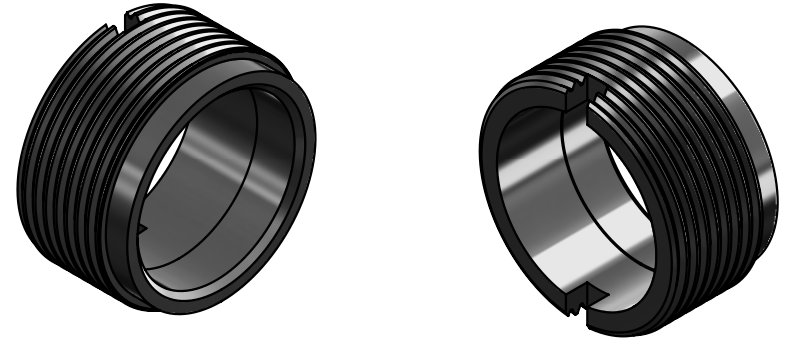

G97 H6 B 5 I 5

F9J	85H9	7B	5A 9B8A 9BHG	A C 8 ± 98 6M
5	% (#\$* #)\$%			
6	& # \$ + # \$ %		G@C HA C J 98	
7	&&#'\$' # \$ &		7 < 5A : 9F '58898žHC @9F5B7 9'7 < 5B; 98	
8	& (#\$- #)\$		*!)!+K 5G, (8)	GA

9B9F5@BCHG
 F9A C J 9 5 @ @ 6 l FFG5B8
 G< 5FD 98: 9G1 B@GG
 C H: 9FK 69 G5H98
 8-A 9BGC BG5F9-B a a fū
 HC@F5B7 9 9 L 7 9DHK < 9F9G5H98.
 BC 897 A 5@DC-BH / '\$*&
 CB9897 A 5@D@5 7 9 / '\$%
 HC C 897 A 5@D@5 7 9G / '\$(\$)
 5B: @G / %

8F5K B	D?	- '9bXYUj ci fFXZ 7 Ufj p[VU\zBGK z&&&- D\''*9&l-) & l-) %& : UI''*9&l-) & l, (& %	
7 < 97 798		5DDFC J 98	
HH@. F95-B9'! 89H9MK 5G<			
A 5H9F 5@ Ø% '\$) '6F5GGFC 8 '5G9) * + # (, *			
: B G<			
HjgXfUk bl jghY 7 cdfj \hcZ 9bk UY 5i gfu JU Dtm@X UbX a Um bc hVY fdfcXi WX jz z cfdUth k hci hAY k fHY b Vebg/bhcZ 9bk UY 5i gfu JU Dtm@X			BK : BC" G< 99H% C : % , - ' (%